



Quick Guide

MG ZS Hybrid+

Contacts and Details

Before starting the journey, it is recommended to read the Owner's Manual on the MG Motor website or iSMART App to understand all the information required for the use of the vehicle.

Always remember that if you have any queries concerning the operation or specification of your car, your MG Authorised Repairer will be glad to advise you.

UK Roadside Assistance Emergency Contact: 0800 072 3338

MG UK Website: www.mg.co.uk

Nearest Authorised Repairer - Consult MG Touchpoint

Company Address:

MG Motor UK Ltd
Lowhill Lane
Birmingham
England
B31 2BQ

Version Details:
Version MG 1.01

If you require MG Assistance please provide the following information when you call:

- Your name
- A contact telephone number (if available)
- Registration, make, model and colour
- Address
- Nature of breakdown
- Exact location

Interior Layout

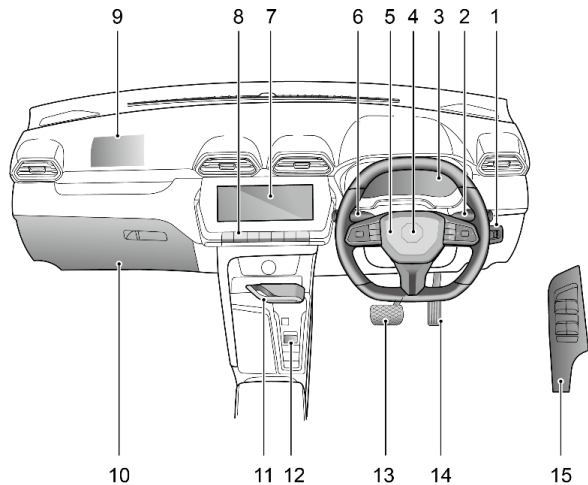

1. Headlamp Levelling & Mirror Adjustment Switch

2. Wiper Stalk Switch

3. Instrument Pack

4. Driver Airbag

5. Horn

6. Indicator/Main Beam Stalk Switch

7. Intelligent Display

8. Instrument Panel Central Switch

9. Passenger Airbag

10. Glovebox

11. Gear Selector

12. Start/Stop Switch

13. Brake Pedal

14. Accelerator Pedal

15. Power Window Switches

* Model Derivative Dependent

Instrument Pack

Type A *

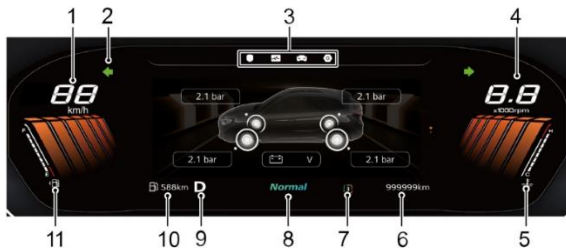

- | | |
|----------------------------------|--------------------------|
| 1. Speedometer | 7. Energy Recovery Level |
| 2. Warning Lights and Indicators | 8. Driving Mode |
| 3. Message Centre | 9. Gear Display |
| 4. Tachometer | 10. Driving Range |
| 5. Engine Coolant Temperature | 11. Fuel Gauge |
| 6. Odometer | |

Please consult Owners Handbook for detailed warning light description and function

Instrument Pack

Type B *

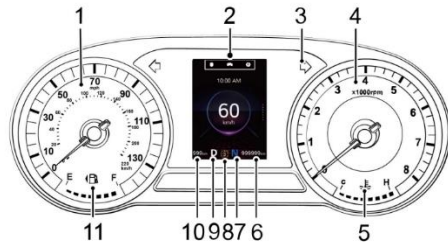

- | | |
|----------------------------------|--------------------------|
| 1. Speedometer | 7. Driving Mode |
| 2. Message Centre | 8. Energy Recovery Level |
| 3. Warning Lights and Indicators | 9. Gear Display |
| 4. Tachometer | 10. Driving Range |
| 5. Engine Coolant Temperature | 11. Fuel Gauge |
| 6. Odometer | |

Please consult Owners Handbook for detailed warning light description and function

Underbonnet Locations

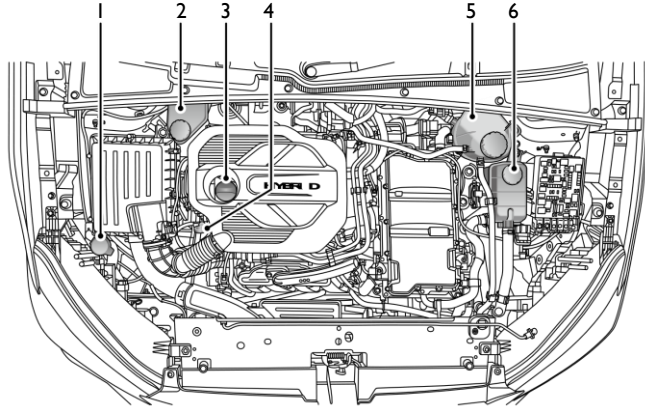

- 1. Washer fluid reservoir
- 2. Brake fluid reservoir
- 3. Engine oil filler

- 4. Engine oil level dipstick
- 5. Engine coolant reservoir
- 6. Hybrid transmission coolant reservoir

Recommended Fluids, Capacities and Pressures

| | | |
|-----------------------------|--------------------------------------|-------------|
| Engine Oil | C5 & SP 0W-20 | 4 Litres |
| Engine Coolant | Glycol (OAT) | 6.4 Litres |
| Hybrid Transmission Coolant | Glycol (OAT) | 3.4 Litres |
| Hybrid Transmission Fluid | Castrol BOT794 | 1.5 Litres |
| Brake Fluid | DOT 4 | 0.85 Litres |
| Washer Fluid | Proprietary Brand Screenwasher Fluid | 2.5 Litres |
| | | |
| Tyre Pressures (cold) | Normal | |
| Front | 2.5 bar (37 psi) | |
| Rear | 2.5 bar (37 psi) | |

Keyless Start

Indicator OFF

- Engine and Power system OFF
- Power seats and mirrors remain operational (model dependant).

Indicator YELLOW

- Pressing Start/Stop switch without footbrake applied enters ACC mode
- Limited electrical equipment operation & power windows

Indicator GREEN

- Pressing Start/Stop switch without footbrake applied whilst in ACC mode - Enters ON Mode
- All electrical equipment will function.

Indicator READY

- Pressing Start/Stop switch from any state with footbrake applied and P selected.
- Enters READY mode, all electrical equipment is functional and car is ready to be driven.



Locking and Unlocking - Keyless

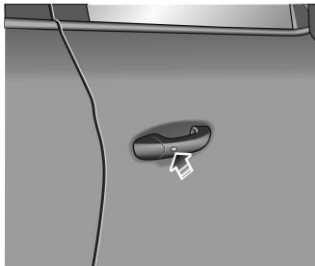

Keyless Locking *

Upon exiting the vehicle, press the button on the front door handle once (no need to press the lock button on the key) to lock all doors before walking away from the car, the vehicle will enter the immobilised/alarm armed state.

Keyless Unlocking *

Press the button on the front door handle once to unlock the car, then pull the door handle to open the door.

Note: With the vehicle in locked state, pressing the button on the front door handle, and performing no other operations within 30 seconds, automatically relocks the car.

When the anti-theft alarm system is not armed or in operation, press the lock switch (1) to lock all doors; press the unlock switch (2) to unlock all doors.

Note: If the anti-theft alarm system is switched on, pressing the lock/unlock button will not lock/unlock the doors but will trigger the alarm system.

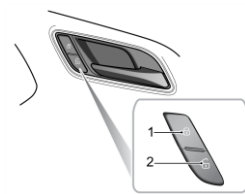

Locking and Unlocking - Key

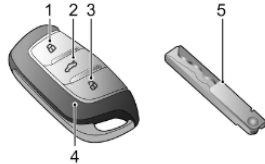

1. Lock button
2. Tailgate release button
3. Unlock button
4. Remote Key
5. Mechanical Key

Key Locking

- Using the remote key to lock: press the Lock button (1) on the smart key to lock the vehicle after closing the doors, bonnet and tailgate.
- Using the mechanical key to lock: remove the driver side door lock trim cover by inserting the key blade into the small recess at the base of the trim, then insert the key into the lock hole and turn counterclockwise to lock the car.

Key Unlocking

- Using the remote key to unlock: press the Unlock button (3) on the key to unlock the vehicle.
- Using the mechanical key to unlock: remove the driver side door lock trim cover by inserting the key blade into the small recess at the base of the trim, then insert the key into the lock hole and turn clockwise to unlock the car.

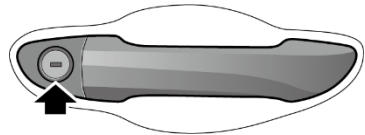

Accessing Owners Literature

Power On/Off

Power On

Pressing the START/STOP Switch to select the ACC or ON/READY position will automatically set the system to power on. If the system is powered off, press and hold the home button on the system control panel for a few seconds, the system will restart automatically.

Power Off

When setting the START/STOP Switch to off, the system will continue to work for a period of time, and then automatically power off. After the vehicle is locked, the system will power off automatically.

1. Home – Short press to return main interface
Long press to restart system
2. Volume Control –
3. Volume Control +



Accessing Owners Literature

Select 'User Manual' in the Main Interface Page, scan the QR code to select your region and download the iSMART APP.

Register and view the user manual.

The full Owners Manual is also available in the Owners Section of www.mg.co.uk

Emergency Starting

Emergency Starting

NEVER attempt to power the vehicle by pushing or towing.

Make sure that both batteries are of the same rated voltage (12 volts), and that the booster cables are approved for use with 12 volt car batteries.

Ensure sparks and naked flames are kept well away from the front compartment.

Ensure that each booster cable connection is securely made. There must be no risk of touching each other or other moving parts, this could cause sparking, which could lead to fire or explosion.

When the low voltage battery loses power, booster cables can be used to connect the battery of a donor vehicle or external battery to start the vehicle.

1. Connect the red booster cable from the positive (+) terminal of the donor battery (A) to positive connecting point (I) on the disabled vehicle (B). Connect the black booster cable from the negative (-) terminal of the donor battery (A) to a good earth point on the disabled vehicle (B), and try to keep it well away from the battery and bypass the fuel and brake lines.

NOTE: Where it is possible to open the tailgate of the disabled vehicle (B), please always give priority to the positive battery terminal as the positive connecting point. If the tailgate cannot be opened, please open the front compartment fuse-box. The terminal shown in figure can be used as the positive connecting point.

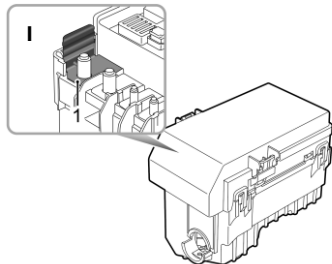

Emergency Starting

Emergency Starting cont

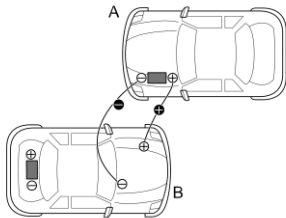

2. Start the donor vehicle and allow it to run for a few minutes.
3. Start the disabled vehicle. If the disabled vehicle does not start after several attempts, it may need to be repaired. Please contact an MG Authorised Repairer.
4. After both the vehicles have normally started/powering, turn off the donor vehicle power.
5. Disconnecting the booster cables must be an exact reversal of the procedure used to connect them, i.e. disconnect the BLACK cable from the earth point on the disabled vehicle FIRST.

IMPORTANT - DO NOT switch on any electrical appliance in the disabled vehicle until the booster cables have been disconnected.

NOTE: It is recommended to turn off the lights, air conditioner and other electrical appliances after starting the vehicle with power loss, and keep the vehicle running for 1~2 hours to restore the battery power. If the battery is fully charged and the vehicle will not start, please contact an MG Authorised Repairer for service.

Towing for Recovery

Vehicle Recovery

Towing for Recovery

Towing Hook



When pushing or towing the vehicle from a dangerous situation or onto the transporter, the speed must remain below 3mph and be completed within 3 minutes.



When pushing or towing the vehicle onto the transporter, the driver's side seat belt should be inserted into the lock and maintained in the inserted state in order to release the EPB.



DO NOT use a tow rope that is twisted - or the towing hook may be unscrewed.



DO NOT tow the vehicle with any of the driven wheels in contact with the road surface, this will avoid electric drive transmission damage.

Your car is equipped with 2 towing eyes (located at the front and rear of the vehicle), they are used for fitting the towing hook.

The towing hook is placed beneath the loadspace floor.

To fit the towing hook, remove the small cover set into the bumper, first press one end of the small cover plate, then open the small cover plate after the other end is lifted, then screw in the towing hook via the small hole into the threaded hole in the bumper beam (see illustration).

Ensure the towing hook is fully tightened!

Note: *The towing eye cover may be secured to the bumper by a plastic cord.*

Towing for Recovery

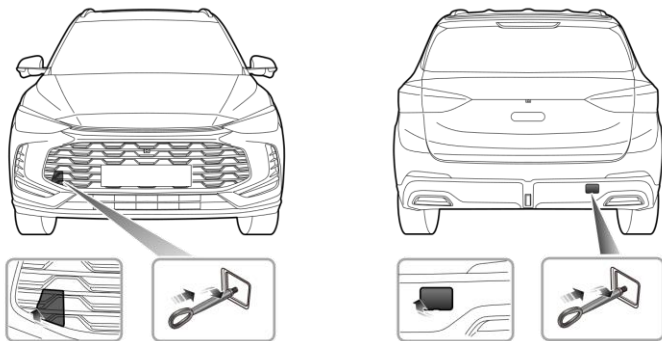

Towing points are intended for use by qualified recovery specialists to assist in the recovery of your car when a breakdown or accident occurs.

They are not designed for towing other vehicles.

The vehicle can be towed using a tow rope but a towing bar is recommended.

NEVER use a twisted tow rope, may cause the towing eye to unscrew.

Towing for Recovery

Towing for Recovery

When towing, DO NOT suddenly accelerate or brake suddenly, this can cause accidents.

Suspended Towing

Suspended towing is the best method for recovering a vehicle that needs to be towed.

The drive wheels **MUST** be suspended above the ground.

Ensure the EPB is released when the rear wheels are in contact with the road surface.

Switch the hazard lamps **ON** and ensure no passengers are in the vehicle.

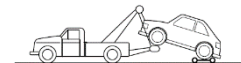

Transporter or Trailer

If your car is to be transported on the back of a trailer or transporter, it must be secured as illustrated:

1. Apply the parking brake and place the electric drive transmission in park.
2. Fit wheel chocks (1) as shown, then position the anti slip rubber blocks (2) around the circumference of the tyre.
3. Fit the lashing straps (3) around the wheels and secure to the trailer. Tighten the straps until the car is securely held.

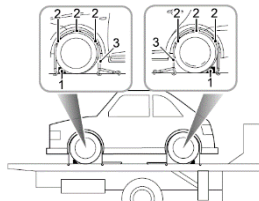

Emergency Tyre Inflation

Tyre Repair

Tool Identification

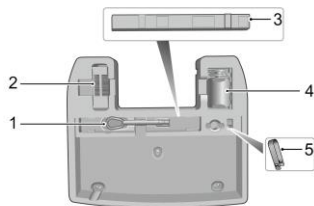

1. Towing Hook
2. Electric Air Pump
3. Warning Triangle
4. Repair Fluid
5. Wheel Bolt Cap Removal Tool

Tyre Repair

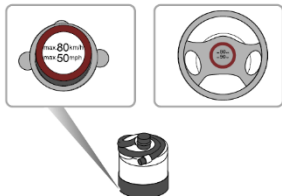

1. Remove the label at the bottom of the repair fluid reservoir and attach it to the steering wheel to remind the driver not to exceed 50 mph.
2. Connect the air hose of the electric air pump to the repair fluid reservoir, fit the tyre sealant bottle (upright) into the slot on the compressor. Remove the valve dust cap of the flat tyre, and connect the filler hose from the tyre sealant bottle to the tyre valve. Ensure that the power switch of the electric air compressor is switched off (i.e., press "O"), then insert the plug from the compressor into the centre console power socket, and turn the vehicle power system to ON/READY.

Emergency Tyre Inflation



3. Switch on the power switch of the electric compressor (i.e., press “-”), to start pumping sealant into the tyre. The tyre sealant bottle will become empty after approximately 30 seconds. The tyre should reach the specified pressure within 5 or 10 minutes.

Note: The pressure gauge may briefly reach 6 bar (87 psi), then the pressure begins to drop to normal.

4. When the required pressure is reached, switch off the power switch of the electric compressor (i.e., press “O”).

Note: If the required pressure cannot be reached within 10 minutes, please disconnect the compressor, drive the vehicle 10 metres (33 feet) approx forward or backward to allow the sealant to spread within the tyre. If the required pressure can still not be reached, the tyre is severely damaged and you should seek assistance from the Roadside Assistance company or an MG Authorised Repairer.

Note: Continual operation of the electric air compressor for more than 10 minutes may result in damage to the compressor.

Note: Under no circumstances should you continue your journey with a deflated tyre. Driving a vehicle with a deflated tyre is extremely dangerous.

5. Remove the tyre sealant bottle from the slot in the compressor, disconnect the hose from the tyre valve, remove the compressor plug from the centre console power socket, return the tyre repair kit to its stowage tray.

After successfully adding sealant to the tyre, drive immediately for a short time (around one minute).

This will allow the sealant to distribute evenly inside the tyre. Continue driving and do not exceed 50 mph. After a further 10 minutes, find a safe place to stop and recheck the tyre pressure.

Emergency Tyre Inflation

Please follow different guidelines based on the tyre pressure measured:

- If the tyre pressure has dropped to less than 0.8 bar (11.6 psi), do not continue driving, seek assistance instead.
- If the tyre pressure is between 0.8 bar (11.6 psi) and specified pressure, use the electric air pump to inflate the tyre until it reaches the specified pressure. Repeat the operations of step 4.
- If the tyre pressure has not dropped, you may continue driving, but the vehicle speed must not exceed 50 mph, and the driving mileage must not exceed 125 miles.

Note: DO NOT remove foreign objects (e.g. screws, nails) from the tyre. The tyre repair system must only be used when the foreign object is in the tread pattern (A).

Note: DO NOT attempt a repair when the damage is in the sidewall of the tyre (B).

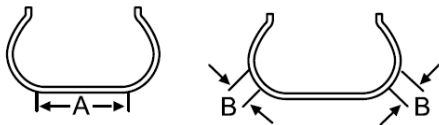

Note: Tyre sealant has an expiry (use by) date, please regularly check the expiry date printed on your sealant bottle and replace as necessary.

